

LC7940YC,7941YC
Dot-matrix LCD Drivers

Overview

The LC7940YC and LC7941YC are segment driver ICs for driving large, dot-matrix LCD displays. They read 4-bit parallel or serial input, display data from a controller into an 80-bit latch, and then generate LCD drive signals corresponding to that data.

The LC7940YC and LC7941YC feature mirror-image pin assignments, allowing them to be used together to increase component density. They are designed to be used with the LC7942YC common driver to drive large LCD panels.

Features

- 80 built-in LCD display drive circuits
- 1/8 to 1/128 display duty cycle
- Serial or 4-bit parallel data input
- Chip disable for low power dissipation for large-sized panels
- Bias supply voltages can be supplied externally
- Operating supply voltage and ambient temperature
 - 2.7 to 5.5 V logic supply (V_{DD}) at $T_a = -20$ to $+85^\circ\text{C}$
 - 8 to 20V LCD supply ($V_{DD} - V_{EE}$) at $T_a = -20$ to $+85^\circ\text{C}$
- CMOS process

Specifications

The following electrical characteristics apply when sealed in a Sanyo standard QIC-100 package.

Absolute Maximum Ratings at $T_a = 25 \pm 2^\circ\text{C}$, $V_{SS} = 0\text{ V}$

Parameter	Symbol	Ratings	Unit
Logic supply voltage	V_{DD} max	-0.3 to +7.0	V
LCD supply voltage, See Note below.	$V_{DD} - V_{EE}$ max	0 to 22	V
Input voltage	V_I max	-0.3 to $V_{DD} + 03$	$^\circ\text{C}$

- Any and all SANYO products described or contained herein do not have specifications that can handle applications that require extremely high levels of reliability, such as life-support systems, aircraft's control systems, or other applications whose failure can be reasonably expected to result in serious physical and/or material damage. Consult with your SANYO representative nearest you before using any SANYO products described or contained herein in such applications.
- SANYO assumes no responsibility for equipment failures that result from using products at values that exceed, even momentarily, rated values (such as maximum ratings, operating condition ranges, or other parameters) listed in products specifications of any and all SANYO products described or contained herein.

LC7940YC, LC7941YC

Parameter	Symbol	Ratings	Unit
Operating temperature range	T_{opr}	-20 to +85	°C
Storage temperature range	T_{stg}	-40 to +125	°C

Note

$$V_{DD} \geq V_1 > V_3 > V_4 > V_{EE}$$

Recommended Operating Conditions at $T_a = -20$ to $+85^\circ\text{C}$, $V_{SS} = 0\text{V}$

Parameter	Symbol	Conditions	Ratings			Unit
			min	typ	max	
Logic supply voltage	V_{DD}		2.7	-	5.5	V
LCD supply voltage	$V_{DD} - V_{EE}$	See Notes 1 and 2.	8	-	20	V
HIGH-level input voltage	V_{IH}	CP, CDI, DI1 to DI3, M, SDI, P/S, DISPOFF and LOAD	$0.8V_{DD}$	-	-	V
LOW-level input voltage	V_{IL}	CP, CDI, DI1 to DI3, M, SDI, P/S, DISPOFF and LOAD	-	-	$0.2V_{DD}$	V
CP shift clock frequency	f_{CP}			-	3.3	MHz
CP pulsewidth	t_{WC}		100	-	-	ns
LOAD pulsewidth	t_{WL}		100	-	-	ns
DI _n and SDI to CP setup time	t_{SETUP}		80	-	-	ns
DI _n and SDI to CP hold time	t_{HOLD}		80	-	-	ns
CP to LOAD time	t_{CL1}		0	-	-	ns
	t_{CL2}		100	-	-	ns
LOAD to CP time	t_{LC}		100	-	-	ns
CP rise time	t_R		-	-	50	ns
CP fall time	t_F		-	-	50	ns
LOAD rise time	t_{RL}		-	-	50	ns
LOAD fall time	t_{FL}		-	-	50	ns

Notes

- $V_{DD} \geq V_1 > V_3 > V_4 > V_{EE}$
- At turn ON, the LCD supply should be energized after or simultaneously with the logic supply. At turn OFF, the logic supply should be cut after or simultaneously with the LCD supply.

Electrical Characteristics at $T_a = 25 \pm 2^\circ\text{C}$, $V_{SS} = 0\text{V}$, $V_{DD} = 2.7$ to 5.5V

Parameter	Symbol	Conditions	Ratings			Unit
			min	typ	max	
HIGH-level input current	I_{IH}	$V_{IN} = V_{DD}$; LOAD, CP, CDI, P/S, DI1 to DI3, SDI, M, and DISPOFF	-	-	1	μA
LOW-level input current	I_{IL}	$V_{IN} = V_{SS}$; LOAD, CP, CDI, P/S, DI1 to DI3, SDI, M, and DISPOFF	-	-	-1	μA
CDO HIGH-level output voltage	V_{OH}	$I_{OH} = -400\ \mu\text{A}$	$V_{DD} - 0.4$	-	-	V
CDO LOW-level output voltage	V_{OL}	$I_{OL} = 400\ \mu\text{A}$	-	-	0.4	V
O1 to O80 driver ON resistance	R_{ON}	$V_{DD} - V_{EE} = 18\text{V}$, $ V_{DE} - V_O = 0.25\text{V}$. See note	-	2	4	$\text{k}\Omega$

LC7940YC, LC7941YC

Parameter	Symbol	Conditions	Ratings			Unit
			min	typ	max	
V_{DD} to V_{SS} standby supply current	I_{ST}	$C_{DI} = V_{DD}$, $V_{DD} - V_{EE} = 18\text{ V}$, $f_{CP} = 3.3\text{ MHz}$, no output load ; V_{SS}	-	-	200	μA
V_{DD} to V_{SS} operating supply current	I_{SS}	$V_{DD} - V_{EE} = 18\text{ V}$, $f_{CP} = 3.3\text{ MHz}$, $I_{LOAD} = 5.156\text{ kHz}$, $f_M = 52\text{ Hz}$; V_{SS}	-	-	1.0	mA
V_{DD} to V_{EE} operating supply current	I_{EE}	$V_{DD} - V_{EE} = 18\text{ V}$, $f_{CP} = 3.3\text{ MHz}$, $f_{LOAD} = 5.156\text{ kHz}$, $f_M = 52\text{ Hz}$; V_{EE}	-	-	0.1	mA
CP input capacitance	C_I	$f_{CP} = 3.3\text{ MHz}$; CP	-	5	-	pF

Note

$V_{DE} = V_1$ or V_3 , or V_4 or V_{EE} , $V_1 = V_{DD}$, $V_3 = 9/11 \times (V_{DD} - V_{EE})$, $V_4 = 2/11 \times (V_{DD} - V_{EE})$

Switching Characteristics at $T_a = 25 \pm 2^\circ\text{C}$, $V_{SS} = 0\text{ V}$, $V_{DD} = 2.7$ to 5.5 V

Parameter	Symbol	Conditions	Ratings			Unit
			min	typ	max	
CDO output delay time	t_D	$C_L = 30\text{ pF}$	-	-	200	ns

Switching Characteristics Waveform

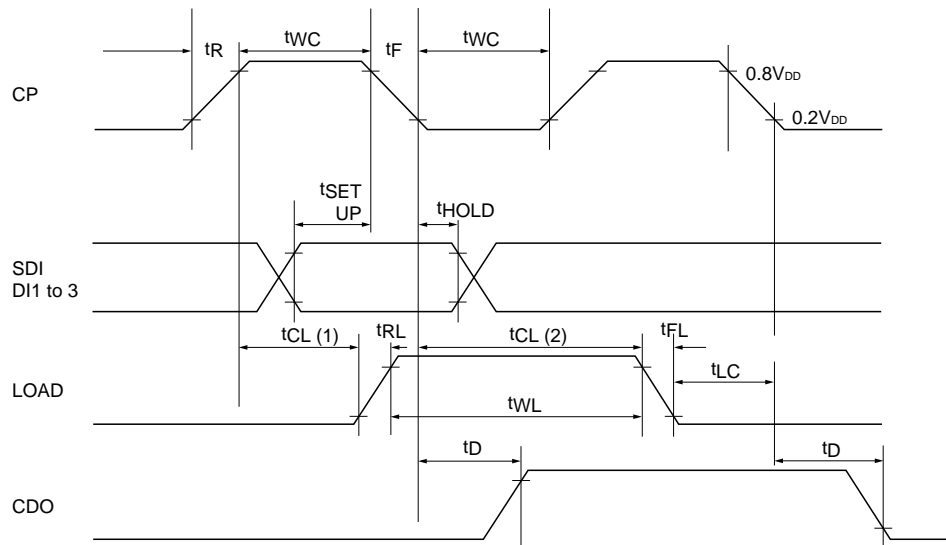

LC7940YC, LC7941YC

Pad Layout (Top view)

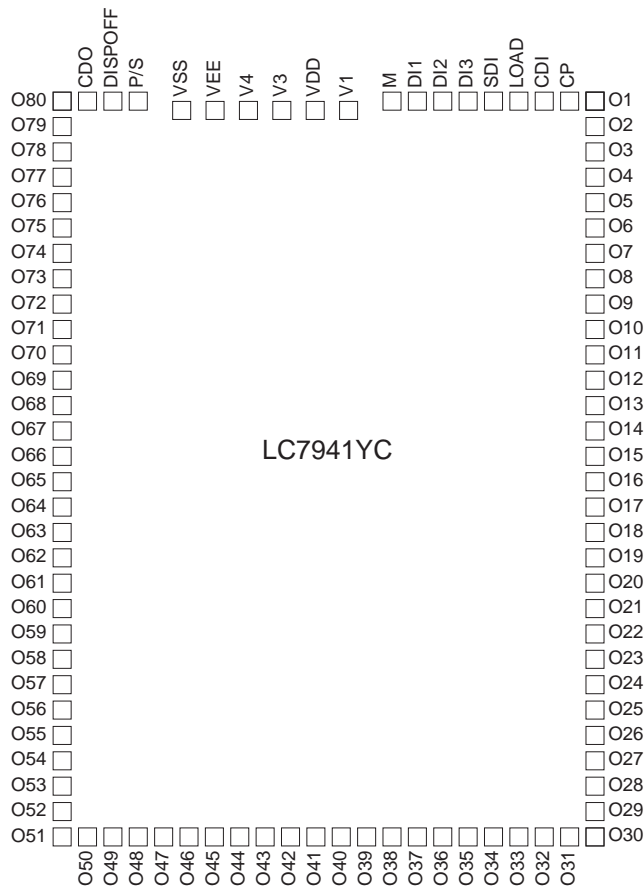
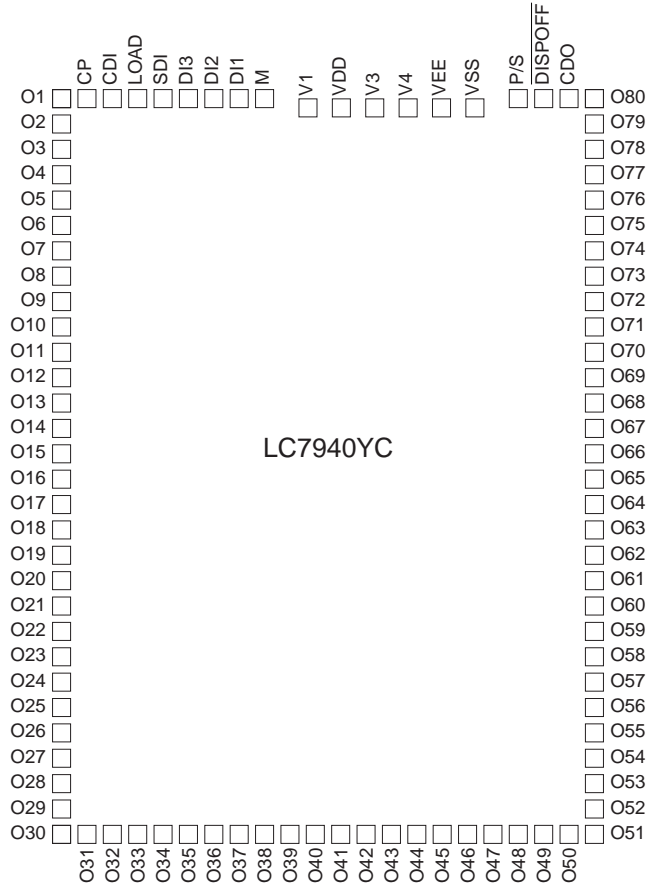

LC7940YC, LC7941YC

LC7940YC Pad Location							
chip size : 4.830 mm x 3.550 mm							
Pin_No.	Name	X	Y	Pin_No.	Name	X	Y
1	O1	-1600	2240	51	O51	1600	-2240
2	O2	-1600	2072	52	O52	1600	-2072
3	O3	-1600	1906	53	O53	1600	-1906
4	O4	-1600	1742	54	O54	1600	-1742
5	O5	-1600	1580	55	O55	1600	-1580
6	O6	-1600	1420	56	O56	1600	-1420
7	O7	-1600	1262	57	O57	1600	-1262
8	O8	-1600	1106	58	O58	1600	-1106
9	O9	-1600	952	59	O59	1600	-952
10	O10	-1600	800	60	O60	1600	-800
11	O11	-1600	650	61	O61	1600	-650
12	O12	-1600	502	62	O62	1600	-502
13	O13	-1600	356	63	O63	1600	-356
14	O14	-1600	212	64	O64	1600	-212
15	O15	-1600	70	65	O65	1600	-70
16	O16	-1600	-70	66	O66	1600	70
17	O17	-1600	-212	67	O67	1600	212
18	O18	-1600	-356	68	O68	1600	356
19	O19	-1600	-502	69	O69	1600	502
20	O20	-1600	-650	70	O70	1600	650
21	O21	-1600	-800	71	O71	1600	800
22	O22	-1600	-952	72	O72	1600	952
23	O23	-1600	-1106	73	O73	1600	1106
24	O24	-1600	-1262	74	O74	1600	1262
25	O25	-1600	-1420	75	O75	1600	1420
26	O26	-1600	-1580	76	O76	1600	1580
27	O27	-1600	-1742	77	O77	1600	1742
28	O28	-1600	-1906	78	O78	1600	1906
29	O29	-1600	-2072	79	O79	1600	2072
30	O30	-1600	-2240	80	O80	1600	2240
31	O31	-1420	-2240	81	---	---	---
32	O32	-1262	-2240	82	CDO	1415	2240
33	O33	-1106	-2240	83	---	---	---
34	O34	-952	-2240	84	DISPOFF	1252	2240
35	O35	-800	-2240	85	P/S	1091	2240
36	O36	-650	-2240	86	V _{SS}	825	2179
37	O37	-502	-2240	87	V _{EE}	629	2179
38	O38	-356	-2240	88	V ₄	464	2179
39	O39	-212	-2240	89	V ₃	299	2179
40	O40	-70	-2240	90	---	---	---
41	O41	70	-2240	91	V _{DD}	123	2179
42	O42	212	-2240	92	V ₁	-42	2179
43	O43	356	-2240	93	M	-316	2240
44	O44	502	-2240	94	DI1	-467	2240
45	O45	650	-2240	95	DI2	-620	2240
46	O46	800	-2240	96	DI3	-775	2240
47	O47	952	-2240	97	SDI	-932	2240
48	O48	1106	-2240	98	LOAD	-1091	2240
49	O49	1262	-2240	99	CDI	-1252	2240
50	O50	1420	-2240	100	CP	-1415	2240

LC7940YC, LC7941YC

LC7941C Pad Location							
chip size : 4.830 mm x 3.550 mm							
Pin No.	Name	X	Y	Pin No.	Name	X	Y
1	O80	-1600	2240	51	O30	1600	-2240
2	O79	-1600	2072	52	O29	1600	-2072
3	O78	-1600	1906	53	O28	1600	-1906
4	O77	-1600	1742	54	O27	1600	-1742
5	O76	-1600	1580	55	O26	1600	-1580
6	O75	-1600	1420	56	O25	1600	-1420
7	O74	-1600	1262	57	O24	1600	-1262
8	O73	-1600	1106	58	O23	1600	-1106
9	O72	-1600	952	59	O22	1600	-952
10	O71	-1600	800	60	O21	1600	-800
11	O70	-1600	650	61	O20	1600	-650
12	O69	-1600	502	62	O19	1600	-502
13	O68	-1600	356	63	O18	1600	-356
14	O67	-1600	212	64	O17	1600	-212
15	O66	-1600	70	65	O16	1600	-70
16	O65	-1600	-70	66	O15	1600	70
17	O64	-1600	-212	67	O14	1600	212
18	O63	-1600	-356	68	O13	1600	356
19	O62	-1600	-502	69	O12	1600	502
20	O61	-1600	-650	70	O11	1600	650
21	O60	-1600	-800	71	O10	1600	800
22	O59	-1600	-952	72	O9	1600	952
23	O58	-1600	-1106	73	O8	1600	1106
24	O57	-1600	-1262	74	O7	1600	1262
25	O56	-1600	-1420	75	O6	1600	1420
26	O55	-1600	-1580	76	O5	1600	1580
27	O54	-1600	-1742	77	O4	1600	1742
28	O53	-1600	-1906	78	O3	1600	1906
29	O52	-1600	-2072	79	O2	1600	2072
30	O51	-1600	-2240	80	O1	1600	2240
31	O50	-1420	-2240	81	CP	1415	2240
32	O49	-1262	-2240	82	CDI	1252	2240
33	O48	-1106	-2240	83	LOAD	1091	2240
34	O47	-952	-2240	84	SDI	932	2240
35	O46	-800	-2240	85	DI3	775	2240
36	O45	-650	-2240	86	DI2	620	2240
37	O44	-502	-2240	87	DI1	467	2240
38	O43	-356	-2240	88	M	316	2240
39	O42	-212	-2240	89	V ₁	42	2179
40	O41	-70	-2240	90	V _{DD}	-123	2179
41	O40	70	-2240	91	---	---	---
42	O39	212	-2240	92	V ₃	-299	2179
43	O38	356	-2240	93	V ₄	-464	2179
44	O37	502	-2240	94	V _{EE}	-629	2179
45	O36	650	-2240	95	V _{SS}	-825	2179
46	O35	800	-2240	96	P/S	-1091	2240
47	O34	952	-2240	97	DISPOFF	-1252	2240
48	O33	1106	-2240	98	---	---	---
49	O32	1262	-2240	99	CDO	-1415	2240
50	O31	1420	-2240	100	---	---	---

LC7940YC, LC7941YC

Block Diagram

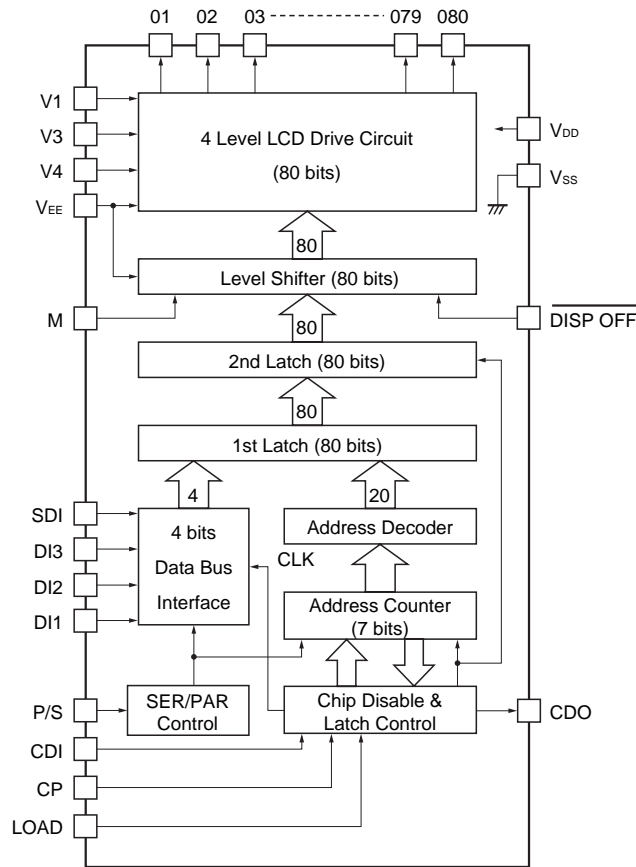

Pin Functions

Pin No.		Symbol	I/O	Function																								
LC7940YC	LC7941YC																											
91	90	V_{DD}	Supply	$V_{DD} - V_{SS}$ is the logic supply. $V_{DD} - V_{EE}$ is the LCD supply.																								
86	95	V_{SS}																										
87	94	V_{EE}																										
92	89	V_1	Supply	LCD panel drive voltage supplies V_1 and V_{EE} are selected levels. V_3 and V_4 are not-selected levels.																								
89	92	V_3																										
88	93	V_4																										
100	81	CP	I	Display data Input clock (falling-edge trigger).																								
99	82	CDI	I	Chip disable. Data is read in when LOW, and not read in when HIGH.																								
98	83	LOAD	I	Display data latch clock (falling-edge trigger). On the falling edge, the LCD drive signals set by the display data are output.																								
97	84	SDI	I	Serial data input.																								
96	85	DI3	I	4-bit parallel data input pins.																								
95	86	DI2																										
94	87	D11				<table border="1" style="width: 100%; text-align: center;"> <thead> <tr> <th colspan="2">Data input</th> <th colspan="3">LCD driver outputs</th> </tr> </thead> <tbody> <tr> <td>SDI</td> <td>O4</td> <td>O8</td> <td rowspan="4" style="font-size: 2em;">→</td> <td>O80</td> </tr> <tr> <td>DI3</td> <td>O3</td> <td>O7</td> <td>O79</td> </tr> <tr> <td>DI2</td> <td>O2</td> <td>O6</td> <td>O78</td> </tr> <tr> <td>DI1</td> <td>O1</td> <td>O5</td> <td>O77</td> </tr> </tbody> </table>	Data input		LCD driver outputs			SDI	O4	O8	→	O80	DI3	O3	O7	O79	DI2	O2	O6	O78	DI1	O1	O5	O77
					Data input		LCD driver outputs																					
			SDI	O4	O8	→	O80																					
			DI3	O3	O7		O79																					
DI2	O2	O6	O78																									
DI1	O1	O5	O77																									
In serial data input mode, DI1 to DI3 should all be tied HIGH or LOW.																												

LC7940YC, LC7941YC

Pin No.		Symbol	I/O	Function																								
LC7940YC	LC7941YC																											
93	88	M	I	LCD panel drive voltage output alternation control signal.																								
85	96	P/S	I	Data input mode select. 4-bit parallel input when HIGH, and serial input when LOW																								
82	99	CDO	O	Cascade connection pin for extension segment drivers. Data is read out when HIGH. Goes LOW after data is read out. Connected to the CDI input of the next chip.																								
1 to 80	80 to 1	O1 to O80	O	LCD drive outputs. The output drive level is determined by the display data, M signal and $\overline{\text{DISP OFF}}$ input as shown below.																								
				<table border="1" style="width: 100%; text-align: center;"> <thead> <tr> <th>M</th> <th>Q</th> <th>$\overline{\text{DISP OFF}}$</th> <th>Output</th> </tr> </thead> <tbody> <tr> <td>LOW</td> <td>LOW</td> <td>HIGH</td> <td>V_3</td> </tr> <tr> <td>LOW</td> <td>HIGH</td> <td>HIGH</td> <td>V_1</td> </tr> <tr> <td>HIGH</td> <td>LOW</td> <td>HIGH</td> <td>V_4</td> </tr> <tr> <td>HIGH</td> <td>HIGH</td> <td>HIGH</td> <td>V_{EE}</td> </tr> <tr> <td>×</td> <td>×</td> <td>LOW</td> <td>V_1</td> </tr> </tbody> </table>	M	Q	$\overline{\text{DISP OFF}}$	Output	LOW	LOW	HIGH	V_3	LOW	HIGH	HIGH	V_1	HIGH	LOW	HIGH	V_4	HIGH	HIGH	HIGH	V_{EE}	×	×	LOW	V_1
				M	Q	$\overline{\text{DISP OFF}}$	Output																					
				LOW	LOW	HIGH	V_3																					
				LOW	HIGH	HIGH	V_1																					
				HIGH	LOW	HIGH	V_4																					
HIGH	HIGH	HIGH	V_{EE}																									
×	×	LOW	V_1																									
Note																												
x = don't care (tied HIGH or LOW)																												
84	97	$\overline{\text{DISPOFF}}$	I	O1 to O80 output control input pin. When LOW, V1 is output on the O1 to O80 outputs, See the truth table.																								
81	91	NC	-	No connection.																								
83	98	NC																										
90	100	NC																										

Application Notes

LCD Panel 1

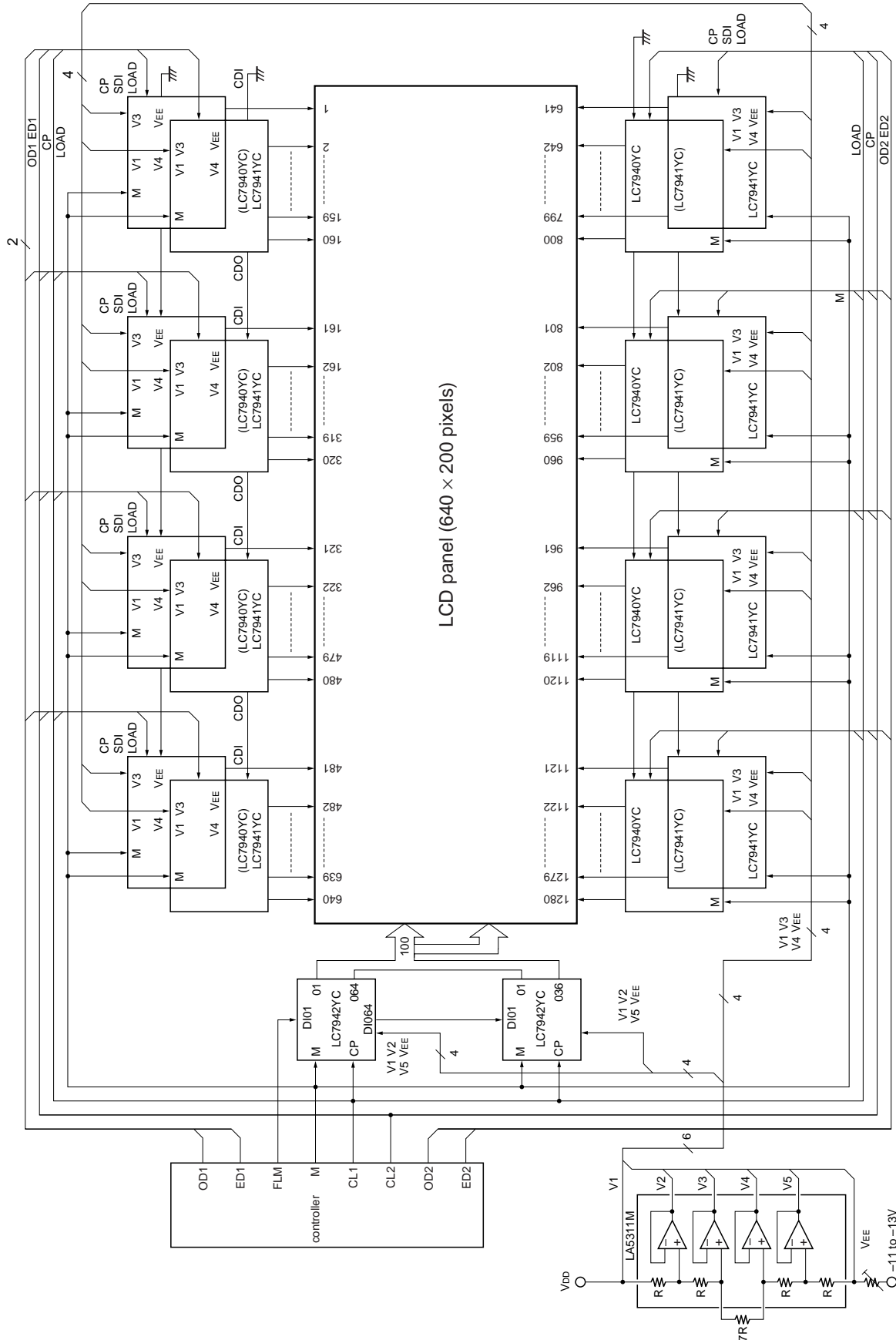

LCD Panel 2

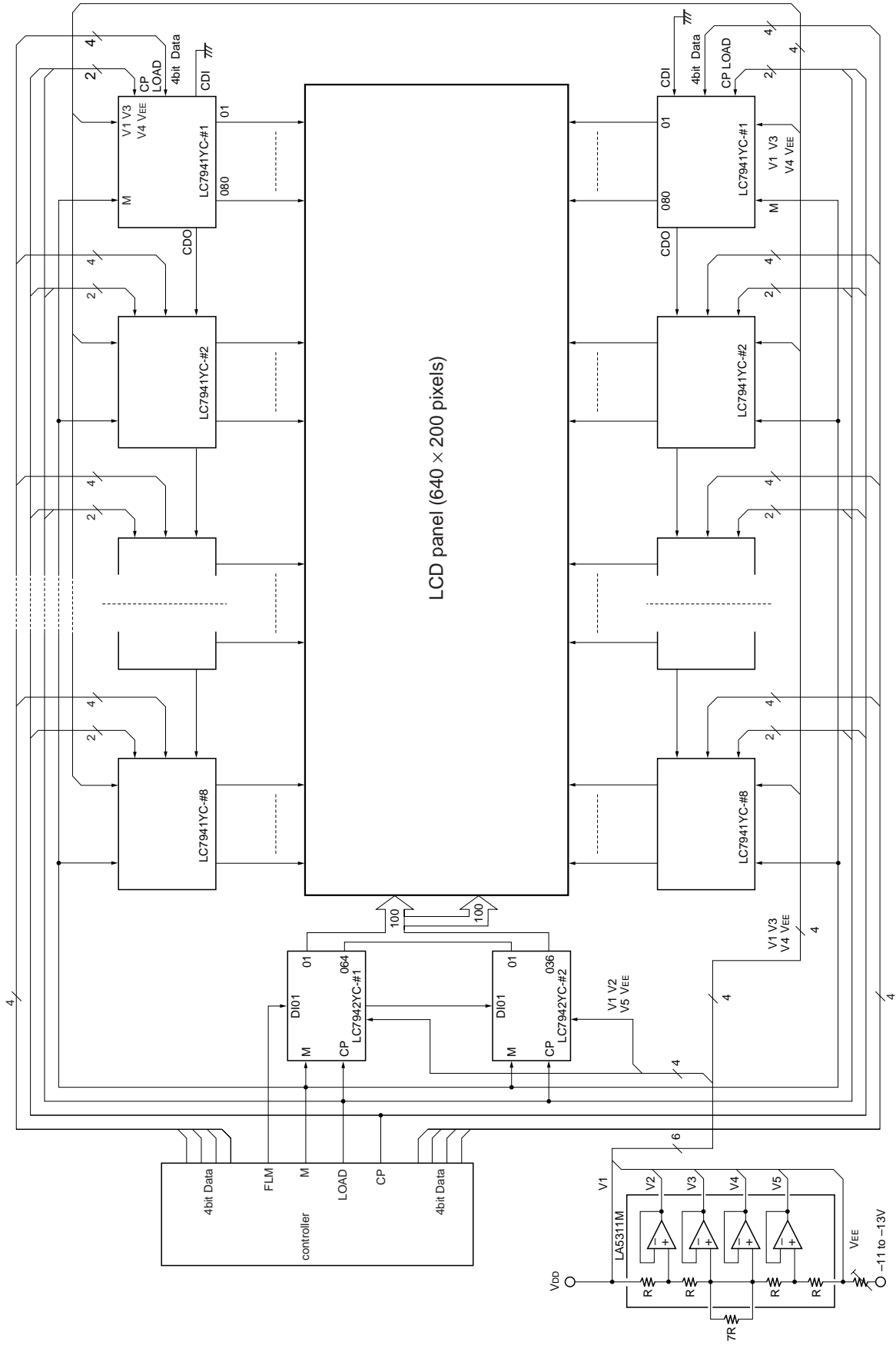

100 x 240-pixel LCD Panel Application

A 100 × 240-pixel LCD panel requires the following drivers.

- 3 x LC7940YC (or LC7941YC) drivers
- 2 x LC7942YC drivers

An example using 1/100 duty cycle is shown below.

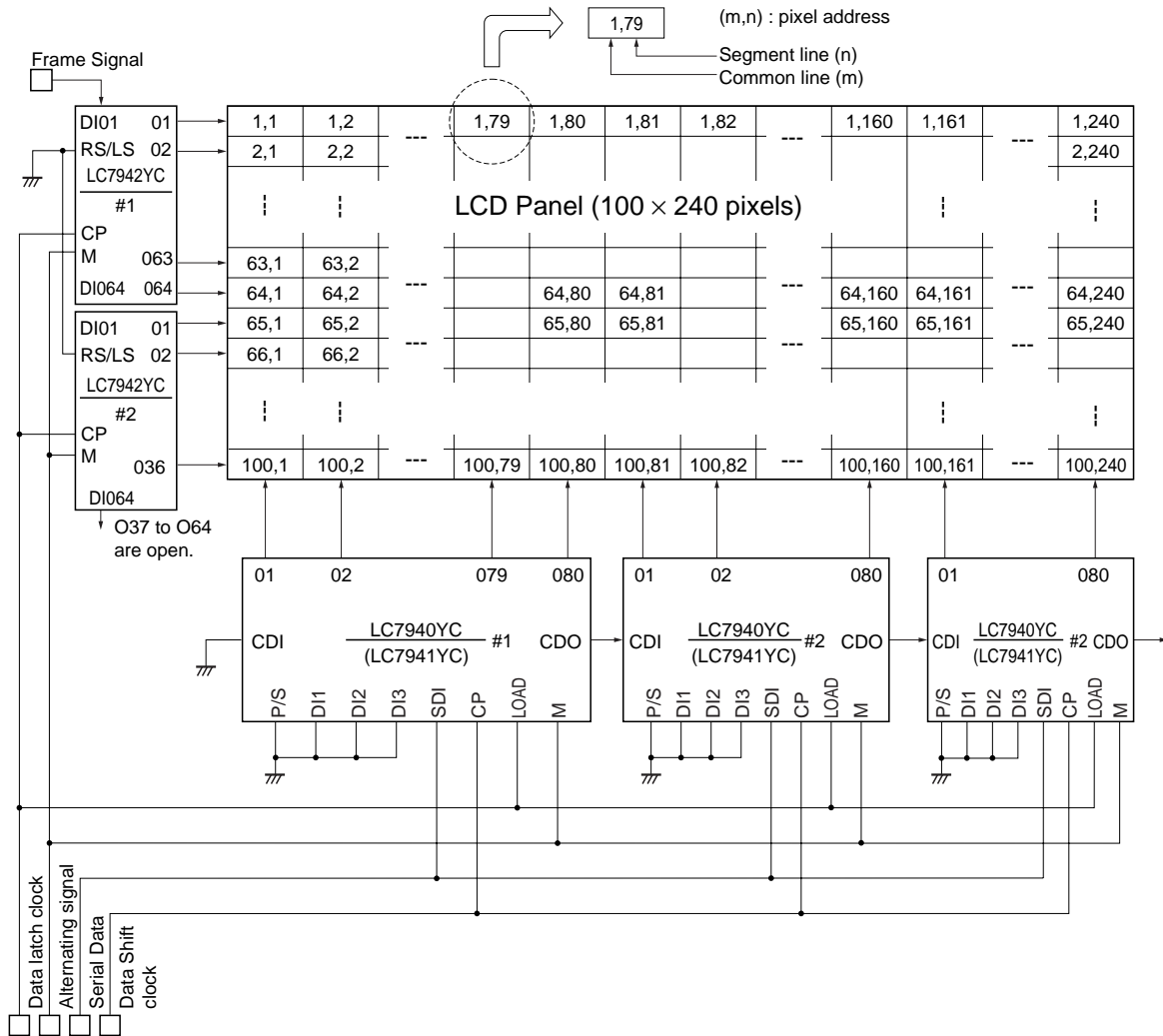

1. The LC7942YC chips are cascaded by connecting DIO64 on chip 1 to DIO1 on chip 2. For a 100-bit shift register, O37 to O64 on chip 2 are left open.
2. The LC7940YC (or LC7941YC) chips are cascaded by connecting CDO on chip 1 to CDI on chip 2, and CDO on chip 2 to CDI on chip 3. CDI on chip 1 is tied to GND, and CDO on chip 3 is not used. This configuration allows the input of 240-bit serial data.

100 x 240-pixel LCD Panel Timing Diagram

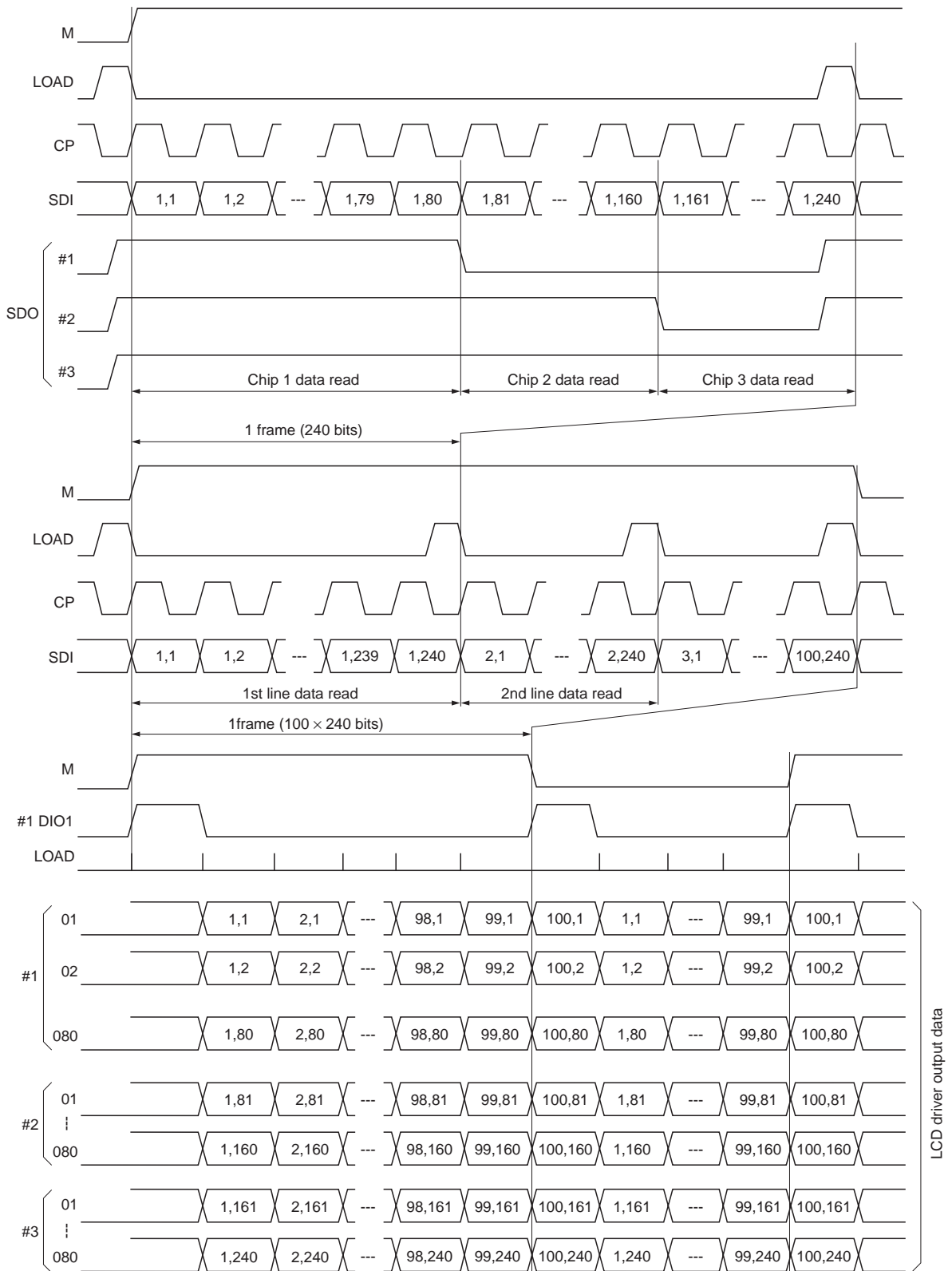

Segment Data Not Multiples of 4

Example.

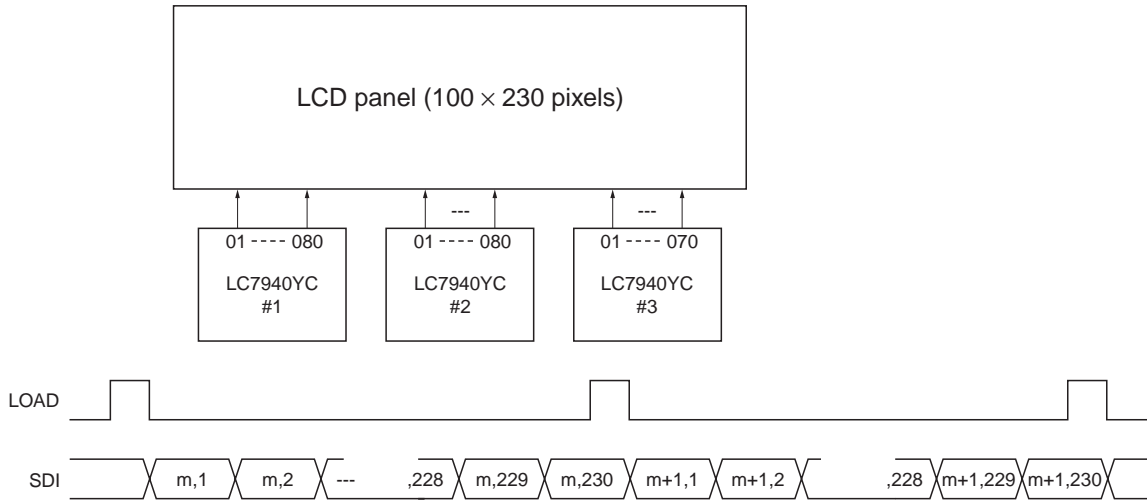

If this timing data is sent, data elements (m, 229), (m, 230), (m+1, 229), (m+1, 230)... will not appear in the output (O69 and O70 on chip 3). This is because the LC7940YC (or LC7941YC) converts serial/parallel data

in 4-bit units, which also decreases power dissipation. For data that is not a multiple of 4, like 230, the following scheme is used.

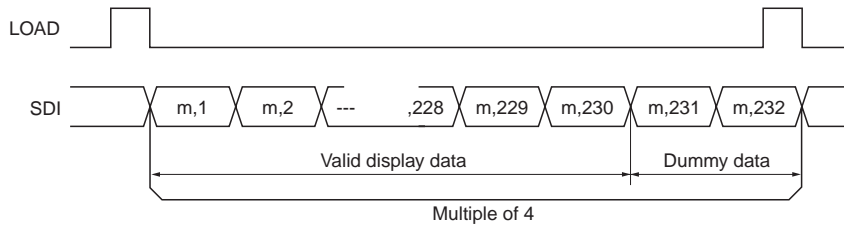

In this case, (m, 231) is output on O71 on chip 3, and (m, 232) on O72 on chip 3. However, these outputs are not connected to the panel and are, therefore, invalid.

- Specifications of any and all SANYO products described or contained herein stipulate the performance, characteristics, and functions of the described products in the independent state, and are not guarantees of the performance, characteristics, and functions of the described products as mounted in the customer's products or equipment. To verify symptoms and states that cannot be evaluated in an independent device, the customer should always evaluate and test devices mounted in the customer's products or equipment.
- SANYO Electric Co., Ltd. strives to supply high-quality high-reliability products. However, any and all semiconductor products fail with some probability. It is possible that these probabilistic failures could give rise to accidents or events that could endanger human lives, that could give rise to smoke or fire, or that could cause damage to other property. When designing equipment, adopt safety measures so that these kinds of accidents or events cannot occur. Such measures include but are not limited to protective circuits and error prevention circuits for safe design, redundant design, and structural design.
- In the event that any or all SANYO products(including technical data, services) described or contained herein are controlled under any of applicable local export control laws and regulations, such products must not be exported without obtaining the export license from the authorities concerned in accordance with the above law.
- No part of this publication may be reproduced or transmitted in any form or by any means, electronic or mechanical, including photocopying and recording, or any information storage or retrieval system, or otherwise, without the prior written permission of SANYO Electric Co., Ltd.
- Any and all information described or contained herein are subject to change without notice due to product/technology improvement, etc. When designing equipment, refer to the "Delivery Specification" for the SANYO product that you intend to use.
- Information (including circuit diagrams and circuit parameters) herein is for example only ; it is not guaranteed for volume production. SANYO believes information herein is accurate and reliable, but no guarantees are made or implied regarding its use or any infringements of intellectual property rights or other rights of third parties.

This catalog provides information as of June, 1999. Specifications and information herein are subject to change without notice.